

LO.NELY 2, 3, 4

Strahler/spotlight/lumière/foco/riflettore

Gebrauchsanleitung/Instruction for use/Notice d'utilisation/ Instrucciones de uso/Instruzioni per l'uso

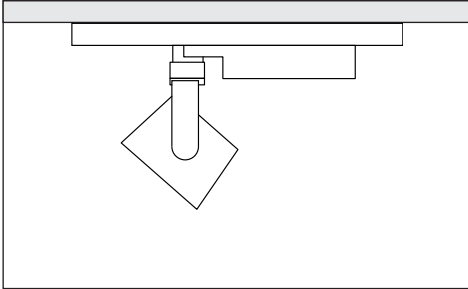

113 3.....
113 3..... D
113 3..... PA
116 5.....
116 5..... D
116 5.....PA

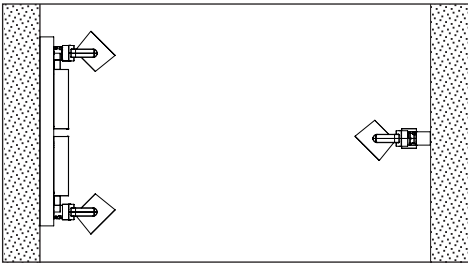

lo.nely 2

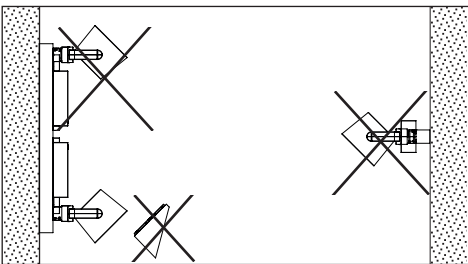

lo.nely 3

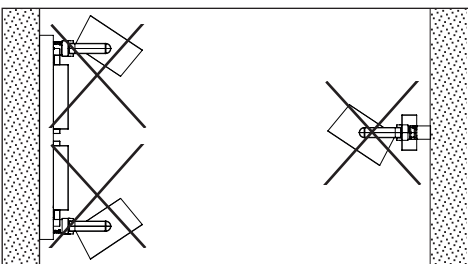

lo.nely 4

LO.NELY 2, 3, 4

Service:

Bei Fragen wenden Sie sich bitte an unsere technische Hotline unter +49 23 55 50 41 26 4 (Montag - Freitag von 08:00 Uhr bis 16:00 Uhr).

Service:

If you have any questions, please contact our technical hotline on +49 23 55 50 41 26 4 (Monday - Friday from 8:00 a.m. to 4:00 p.m.).

Service:

Si vous avez des questions, veuillez vous adresser à notre hotline technique en téléphonant au +49 23 55 50 41 26 4 (du lundi au vendredi, de 8h à 16h).

Servicio técnico:

En caso de consultas, utilice nuestra línea de atención técnica preferente +49 23 55 50 41 26 4 (lunes - viernes desde las 08:00 hasta 16:00 horas)

Servizio di assistenza:

Per maggiori informazioni rivolgetevi al nostro servizio tecnico di assistenza digitando il numero +49 23 55 50 41 26 4 (orari di apertura: da lunedì fino a venerdì dalle ore 08.00 fino alle ore 16.00).

**Ersetze jede gebrochene Schutzscheibe!
Nicht ohne Schutzscheibe betreiben!**

Replace any broken cover glass!
Do not operate without cover glass!

Remplacer chaque verre protecteur cassé!
Ne pas utiliser sans verre protecteur!

Sustituir cada vidrio averiado!
No se utiliza sin vidrio de cubierta!

Sostituire ogni vetro di protezione danneggiato!
Non utilizzare senza vetro di protezione!



Original HOFFMEISTER-Produkt - deshalb nur Original HOFFMEISTER-Teile verwenden.

This is a genuine HOFFMEISTER product - therefore use genuine HOFFMEISTER parts only.

Ceci est un produit d'origine HOFFMEISTER. N'utiliser donc que des pièces d'origine HOFFMEISTER.

Éste es un producto original HOFFMEISTER - por tal razón, utilizar únicamente piezas originales HOFFMEISTER

Prodotto originale HOFFMEISTER - utilizzare pertanto esclusivamente ricambi originali HOFFMEISTER

Bei LED Leuchten kein Lampenwechsel nötig!

Lamp exchange is not necessary for LED version!

Pour la version avec LED l'échange de la lampe n'est pas nécessaire!

Per la versione con LED il cambiamento di lampade n'è necessario!

Para la version con LED no es preciso el cambio de lámparas!

Bei 41W Variante keine Zubehörgläser verwenden!

Use at 41W variant no accessories glasses!

Utilisez-le à la variante 41W pas d'accessoires lunettes!

Utilizzare a variante 41W senza accessori occhiali!

El uso en la variante 41W no accesorios gafas!

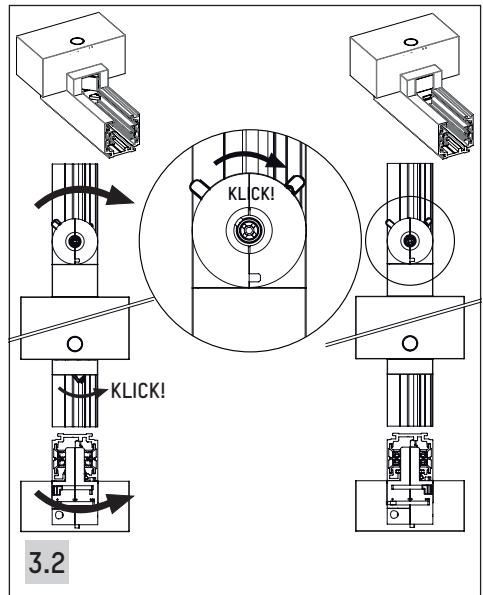
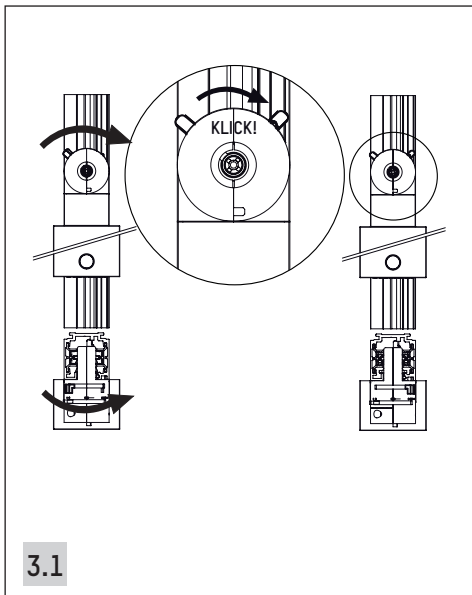
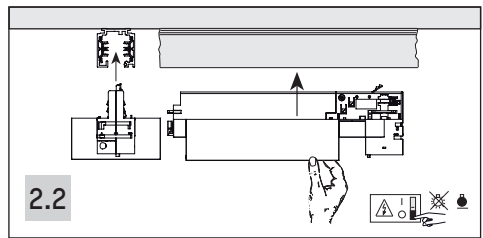
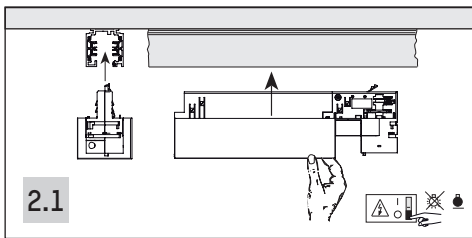
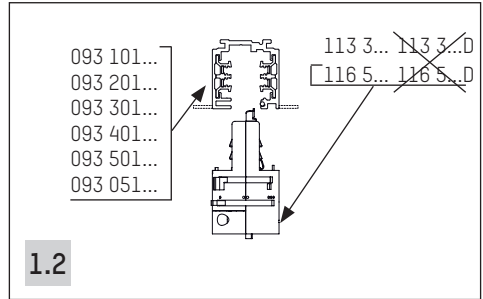
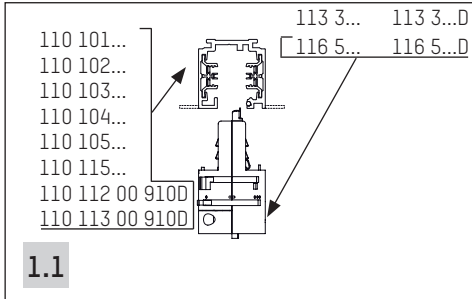

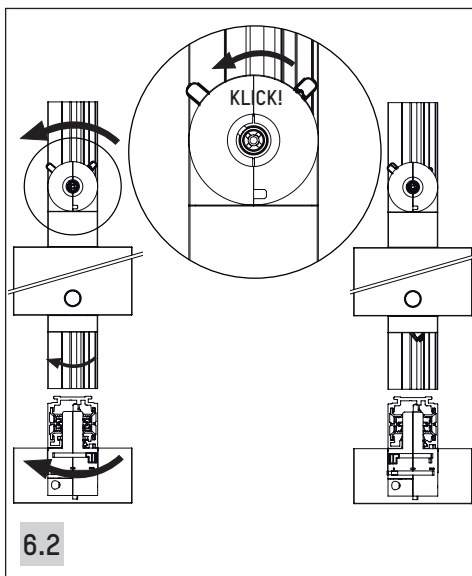
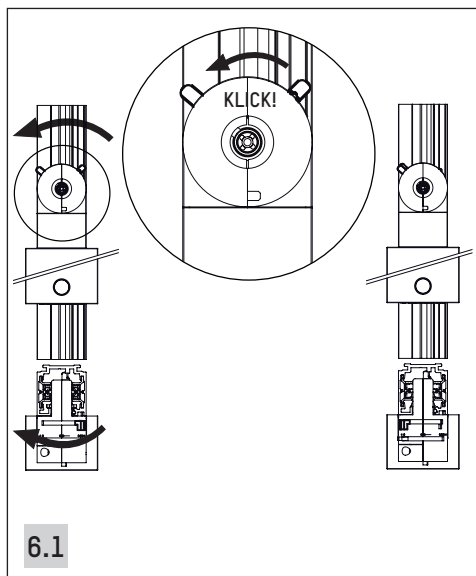
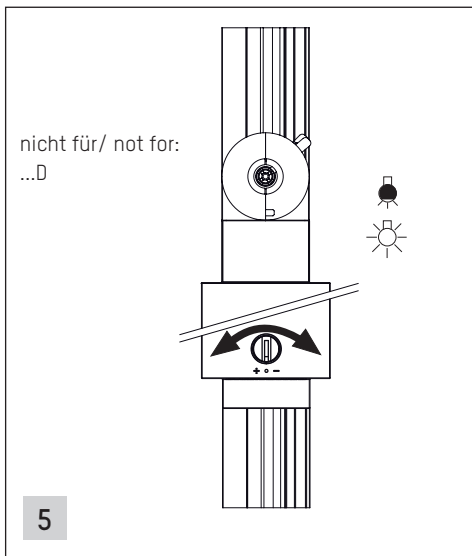
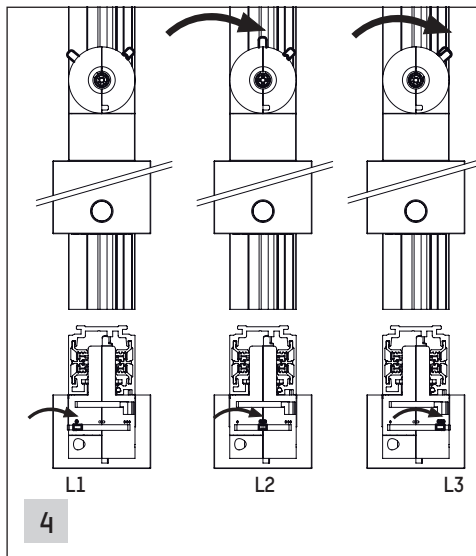

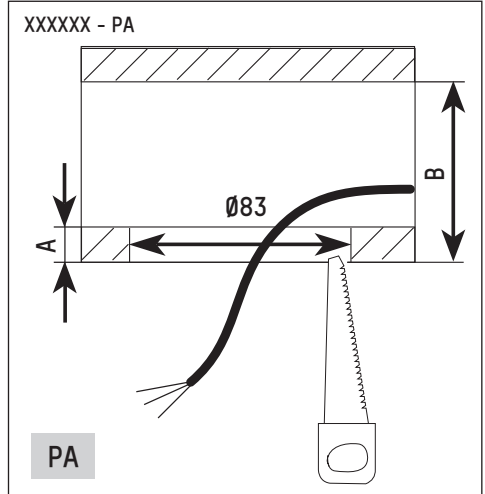
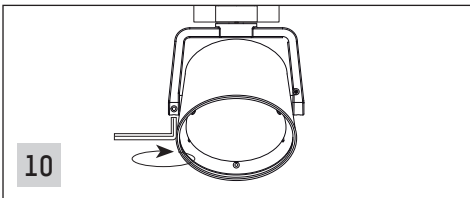
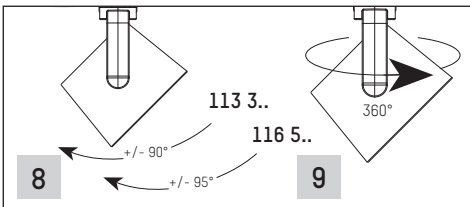
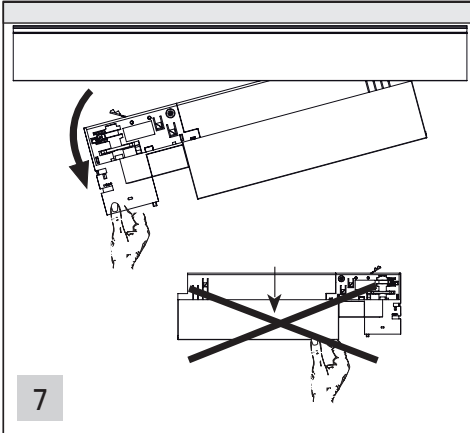

| | | A=3mm | A=12.5mm | A=25mm | A=30mm |
|------------------|----|-------|----------|--------|--------|
| Gr.2 | B= | 63mm | 63mm | 63mm | 66mm |
| Gr.3 | B= | 90mm | 103mm | 120mm | 127mm |
| Gr.4 (35W) | B= | 90mm | 103mm | 120mm | 127mm |
| Gr.4 (55/69W) | B= | 100mm | 115mm | 130mm | 135mm |

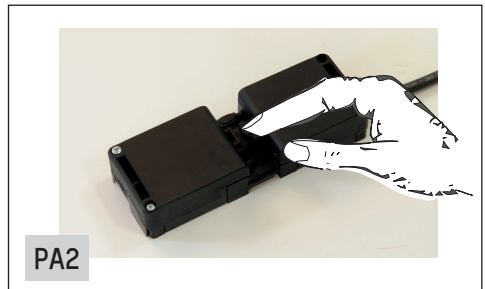

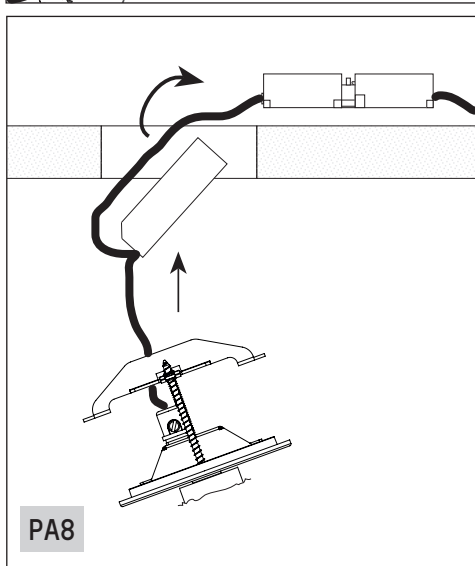
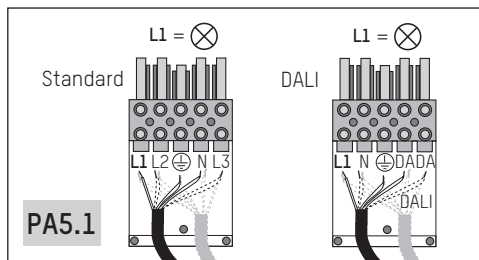
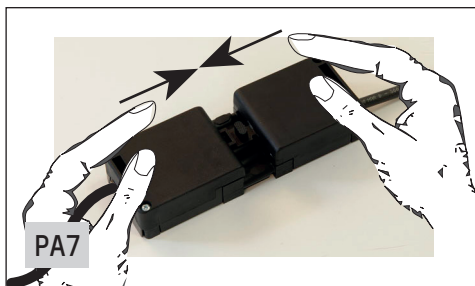
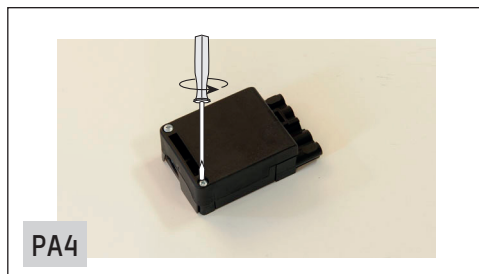
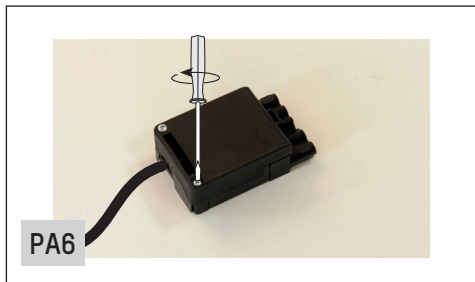
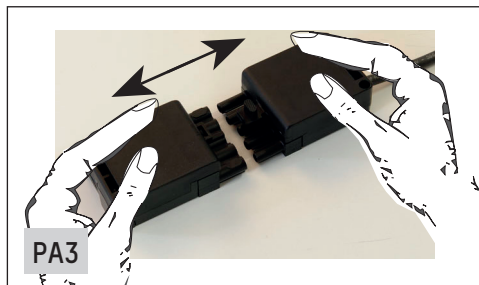

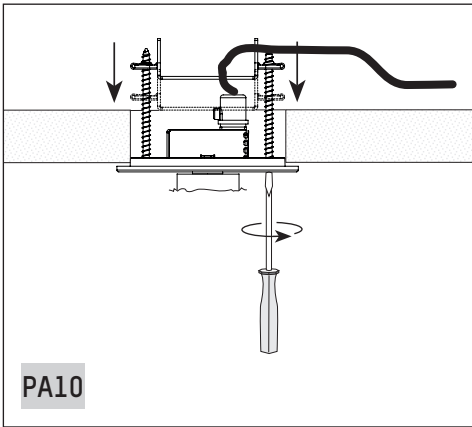
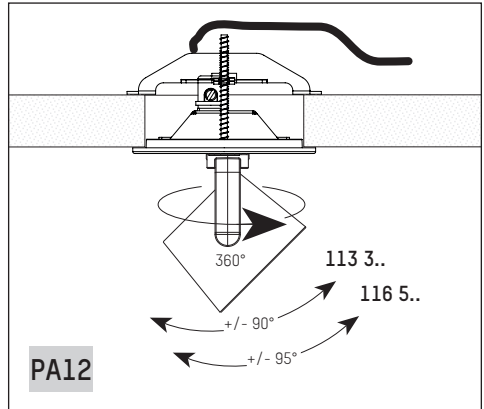
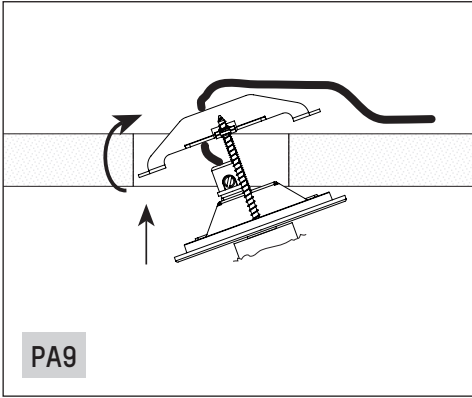

Linsenwandfluter/ lens wall washer

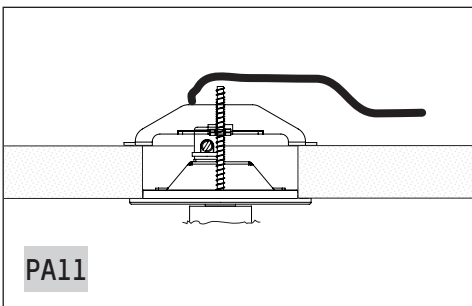
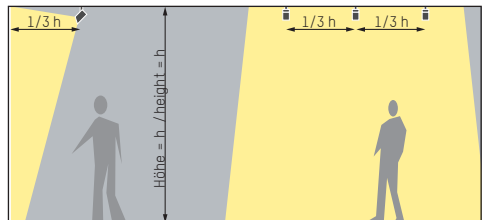

HOFFMEISTER

Hoffmeister GmbH

Gewerbering 28-32
58579 Schalksmühle
Germany
Telefon +49 (0) 2355-50 41-0
Telefax +49 (0) 2355-50 41-328
www.hoffmeister.de
mail@hoffmeister.de

Original **HOFFMEISTER**-Produkt - deshalb nur Original **HOFFMEISTER** - Teile verwenden.

This is an original **HOFFMEISTER** product - therefore use original **HOFFMEISTER** parts only.

Ceci est un produit d'origine **HOFFMEISTER** - pour cette raison, utilisier uniquement des pièces d'origine **HOFFMEISTER**.

Eso es un producto original **HOFFMEISTER** - por eso utilizar solamente piezas de recambio originales **HOFFMEISTER**.

Questo è un prodotto originale **HOFFMEISTER** - per questo impiegare esclusivamente ricambi originali **HOFFMEISTER**.

Unsere Gewährleistung gilt nur bei Beachtung dieser Produktinformation.

Sie erlischt insbesondere bei:

- Nichteinhaltung der Montagehinweise
- Veränderung der Leuchte
- Nichtbeachtung der Einbaumaße

Our guarantee is contingent upon the observance of this product information.

In particular it does not apply in cases of:

- noncompliance with mounting instructions
- modification of the luminaire
- nonrespect of recessing dimensions

Notre garantie dépend de l'observation de cette information sur le produit.

Elle s'éteint notamment dans les cas suivants:

- non-observation des instructions de montage
- modification du luminaire
- non-respect des dimensions d'encastrement

Nuestra garantía depende de la observación de esta información sobre el producto.

Prescribe particularmente en los casos siguientes:

- no observación de las instrucciones de montaje
- modificación de la luminaria
- inobservancia de las dimensiones de empotrado

Nostra garanzia è dipendente della osservanza di questa informazione di prodotto.

Perde la validità particolarmente nel caso di:

- inosservanza dei istruzioni di montaggio
- modificazione dell'apparecchio di illuminazione
- inosservanza dei dimensioni di incasso

Diesen Kontrollschein bei Reklamationen bitte mit zurückschicken.
In case of complaints please return this control label with the product.
En cas de réclamation veuillez retourner cette fiche de contrôle avec le produit.
En caso de reclamaciones, sirvase devol-vernós este talón de inspección junto con el producto.
Rispedire questa bolletta di controllo insieme con il prodotto in caso di reclamo.

Produktions-Serie
Production series
Série de production
Serie de producción
Serie di produzione