

COMPLX.100 R/RD IP20

HOFFMEISTER

Einbauleuchte / Recessed luminaire / Encastré /
Plafón empotrable / Apparecchio di illuminazione da incasso

Gebrauchsanleitung / Instruction for use / Notice d'utilisation /
Instrucciones de uso / Istruzioni per l'uso

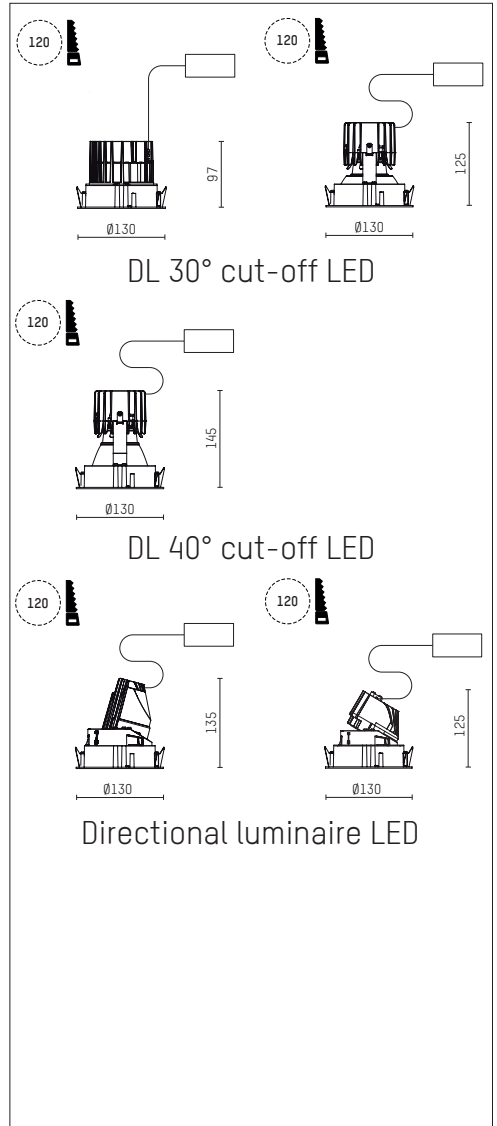
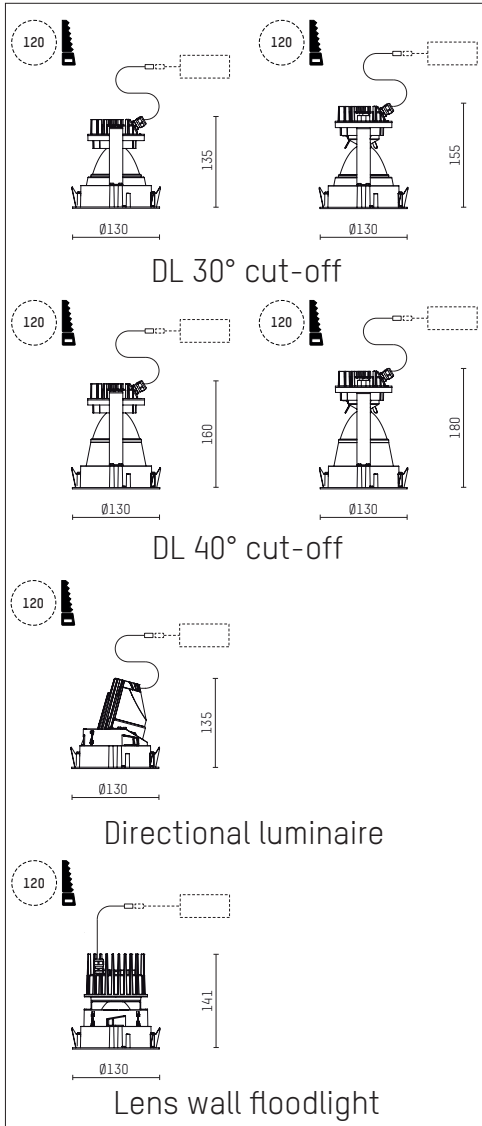

COMPLX.100

Lieferumfang/ scope of supply/ contenu de la livraison/ volumen de suministro/ volume di consegna

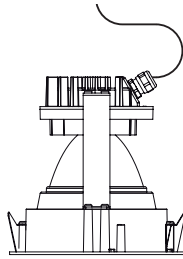

Service:

Bei Fragen wenden Sie sich bitte an unsere technische Hotline unter +49 23 55 50 41 26 4 (Montag - Freitag von 08:00 Uhr bis 16:00 Uhr).

Service:

If you have any questions, please contact our technical hotline on +49 23 55 50 41 26 4 (Monday - Friday from 8:00 a.m. to 4:00 p.m.).

Service:

Si vous avez des questions, veuillez vous adresser à notre hotline technique en téléphonant au +49 23 55 50 41 26 4 (du lundi au vendredi, de 8h à 16h).

Servicio técnico:

En caso de consultas, utilice nuestra línea de atención técnica preferente

+49 23 55 50 41 26 4
(lunes - viernes desde las 08:00 hasta 16:00 horas)

Servizio di assistenza:

Per maggiori informazioni rivolgetevi al nostro servizio tecnico di assistenza digitando il numero +49 23 55 50 41 26 4 (orari di apertura: da lunedì fino a venerdì dalle ore 08.00 fino alle ore 16.00).

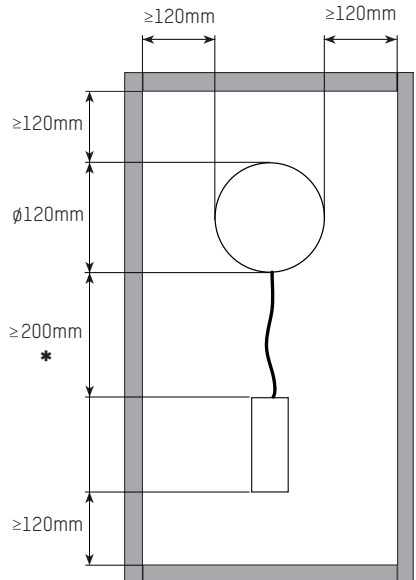

* 460mm (DIR QT12 45W/60W RE; QR-CBCRE)

COMPLX.100

DL 30° cut-off

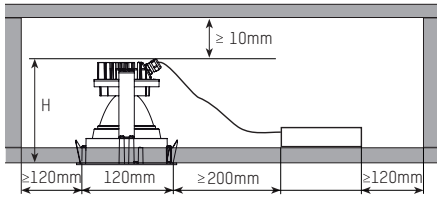

- H= 135mm (DL30°co. HIT GU6.5/QT12/QR-CBCRE)
- H= 155mm (DL30°co. HIT G8.5)
- H= 97mm (DL30°co. LED 6-er)
- H= 125mm (DL30°co. LED Misch)

Leuchte und Versorgungseinheit nicht mit Wärmedämm-Material abdecken
 Do not cover recessed luminaire or power supply unit with warmth insulation material
 Ne couvriez pas le luminaire et l'appareil d'alimentation avec matériel d'isolation



No cubre la lámpara y el aparato de alimentación con material termoaislante
 Lampada e unità d'alimentazione non coprire con materiale per isolamento termico

Directional luminaire / DIR

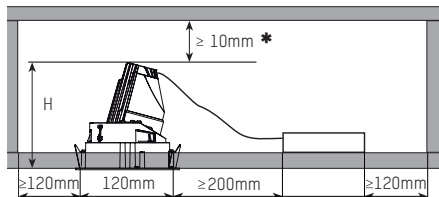

- H= 135mm (DIR HIT GU6.5/QT12/QR-CBCRE/LED 1-er, 4-er)
- H= 125mm (DIR LED 6-er)
- * 85mm (QT12 45W/60W RE; QR-CBCRE)**

Leuchte und Versorgungseinheit nicht mit Wärmedämm-Material abdecken
 Do not cover recessed luminaire or power supply unit with warmth insulation material
 Ne couvriez pas le luminaire et l'appareil d'alimentation avec matériel d'isolation



No cubre la lámpara y el aparato de alimentación con material termoaislante
 Lampada e unità d'alimentazione non coprire con materiale per isolamento termico

DL 40° cut-off

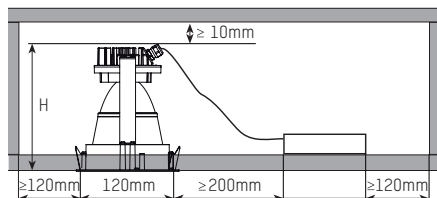

- H= 160mm (DL40°co. HIT GU6.5/QT12)
- H= 180mm (DL40°co. HIT G8.5)
- H= 145mm (DL40°co. LED Misch)

Leuchte und Versorgungseinheit nicht mit Wärmedämm-Material abdecken
 Do not cover recessed luminaire or power supply unit with warmth insulation material
 Ne couvriez pas le luminaire et l'appareil d'alimentation avec matériel d'isolation



No cubre la lámpara y el aparato de alimentación con material termoaislante
 Lampada e unità d'alimentazione non coprire con materiale per isolamento termico

Lens wall floodlight / LWF

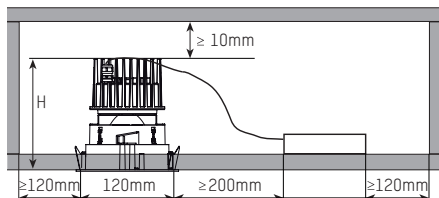

- H= 141mm (LWF HIT GU6.5/QT12)

Leuchte und Versorgungseinheit nicht mit Wärmedämm-Material abdecken
 Do not cover recessed luminaire or power supply unit with warmth insulation material
 Ne couvriez pas le luminaire et l'appareil d'alimentation avec matériel d'isolation



No cubre la lámpara y el aparato de alimentación con material termoaislante
 Lampada e unità d'alimentazione non coprire con materiale per isolamento termico

COMPLX.100

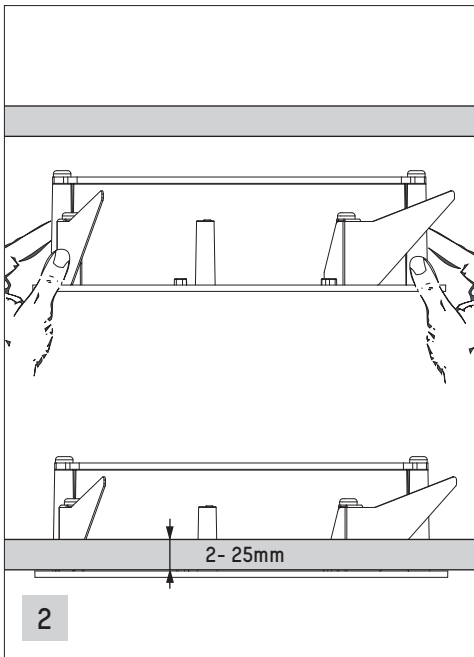
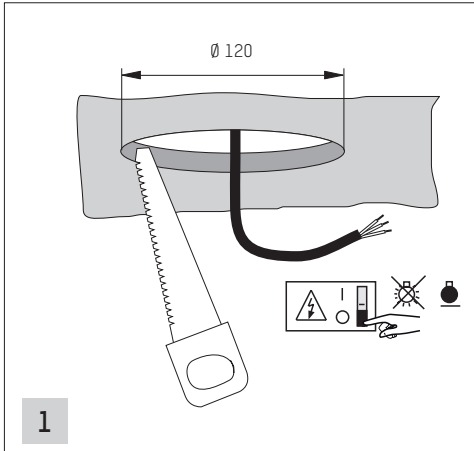

LED

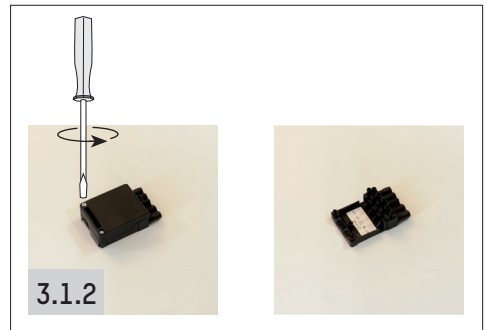
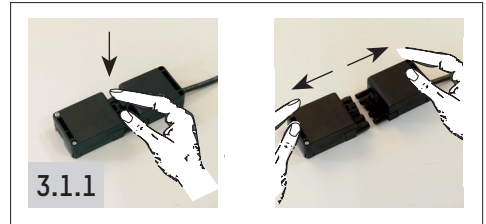
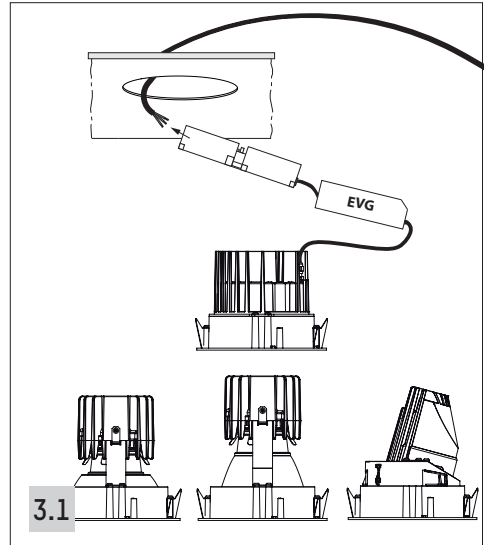

COMPLX.100

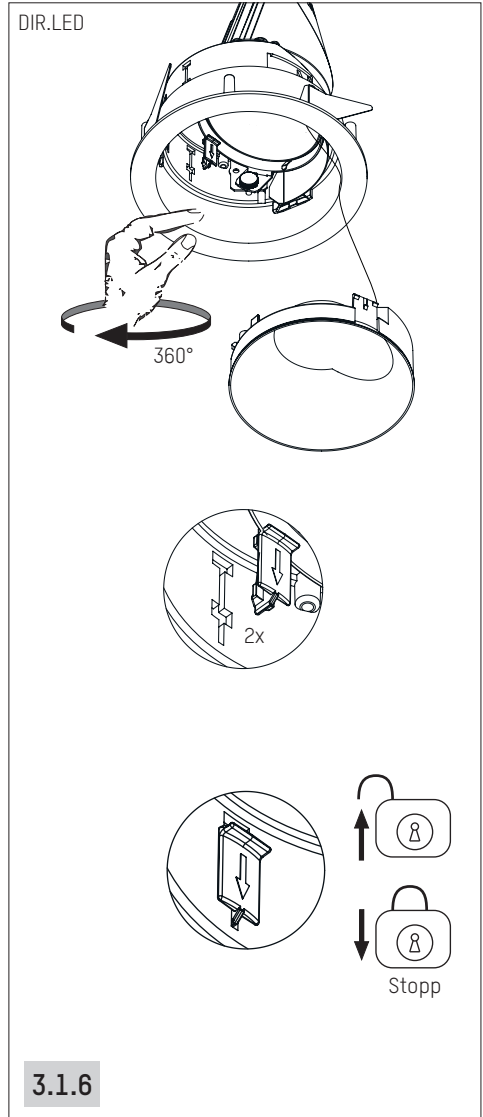
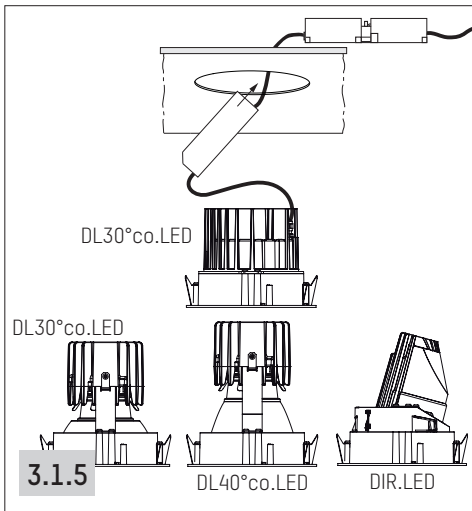
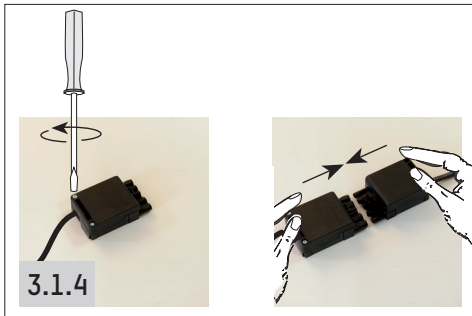
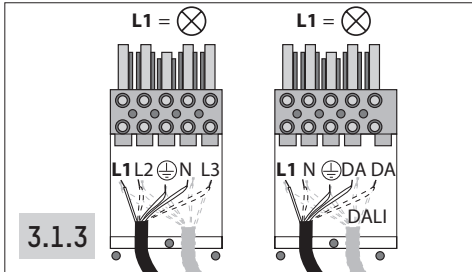

COMPLX.100



DL30°co.

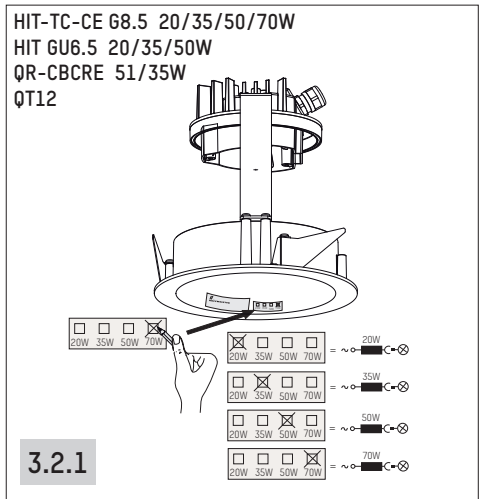
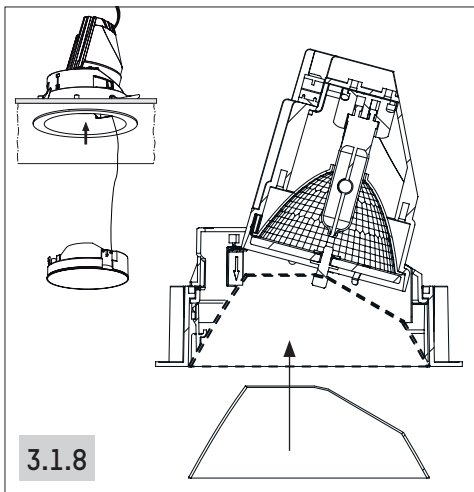
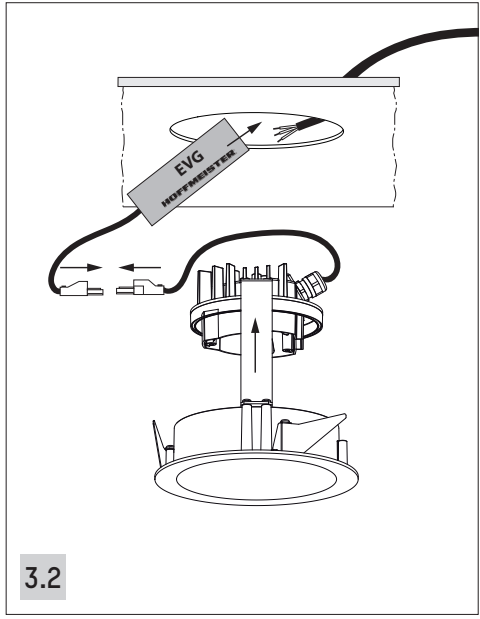
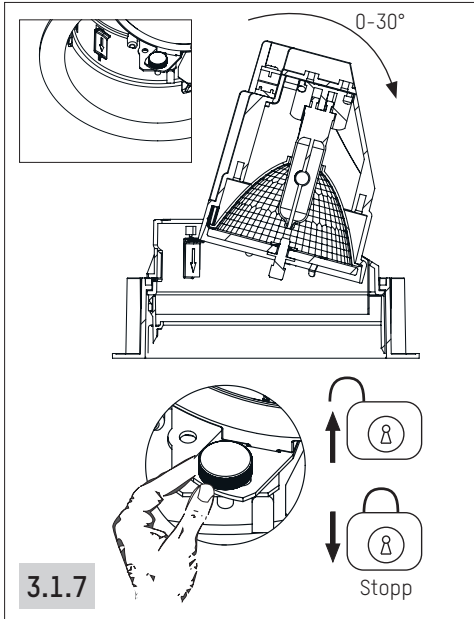

COMPLX.100



DL40°co.

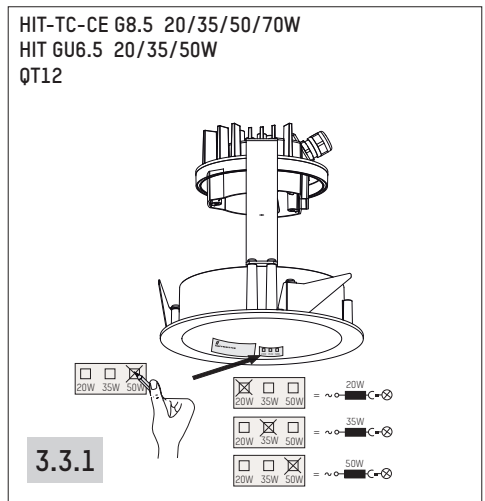
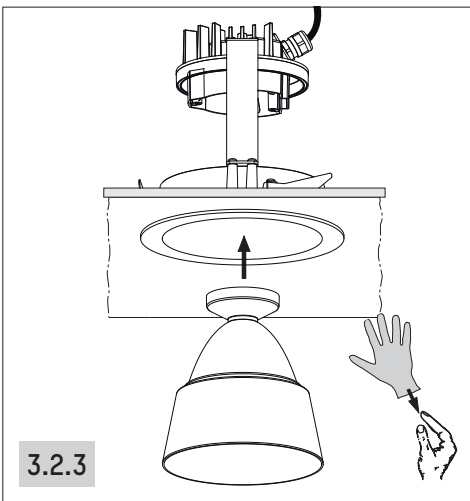
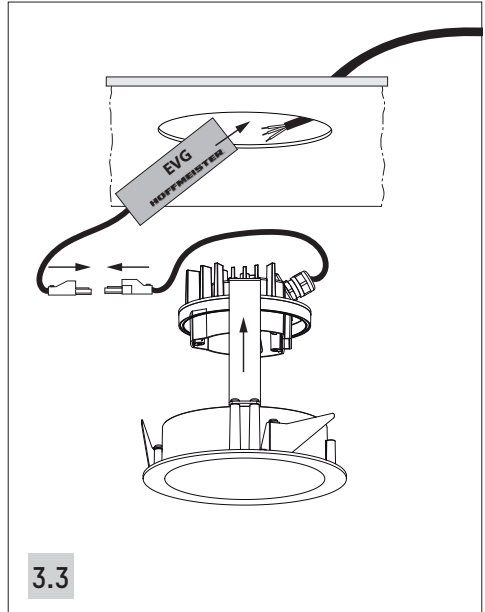
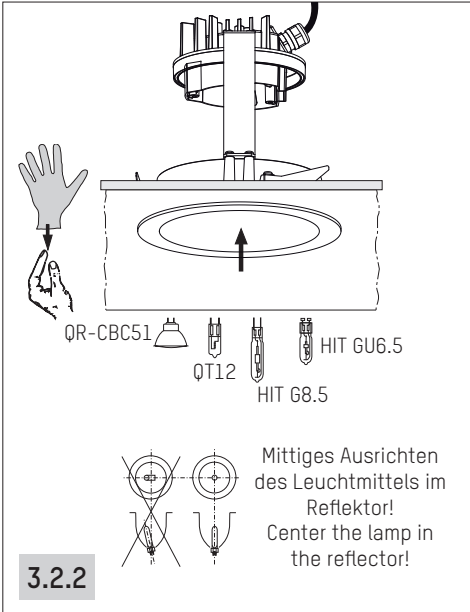

COMPLX.100

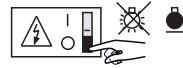

LWF/ lens wall floodlight

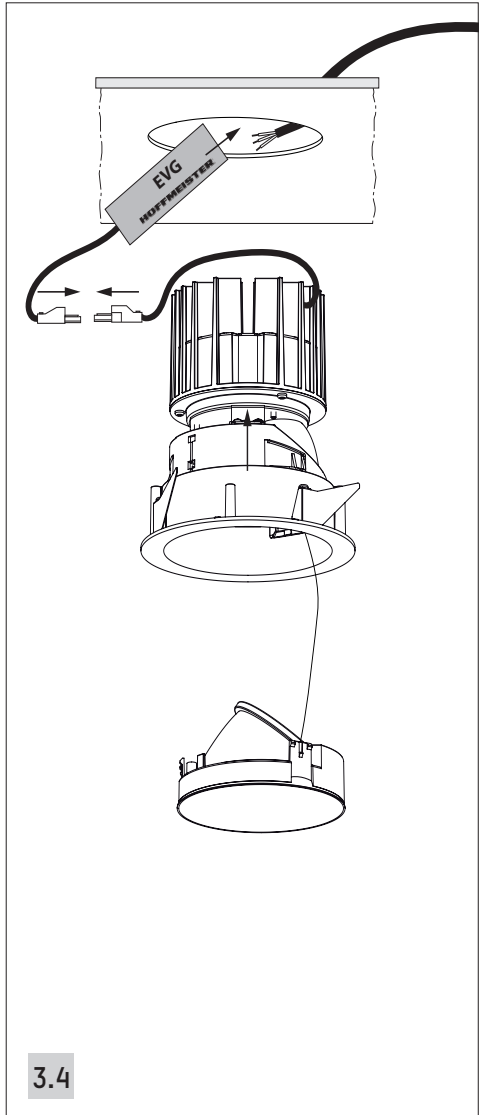
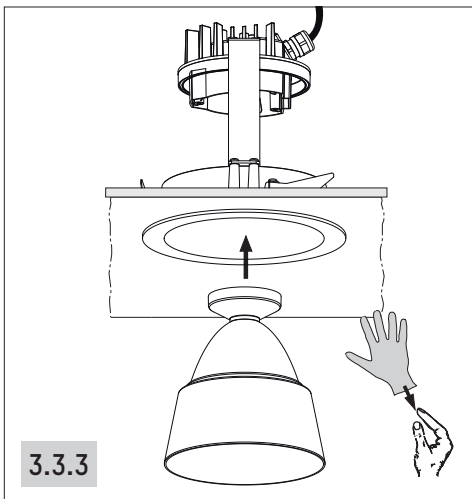
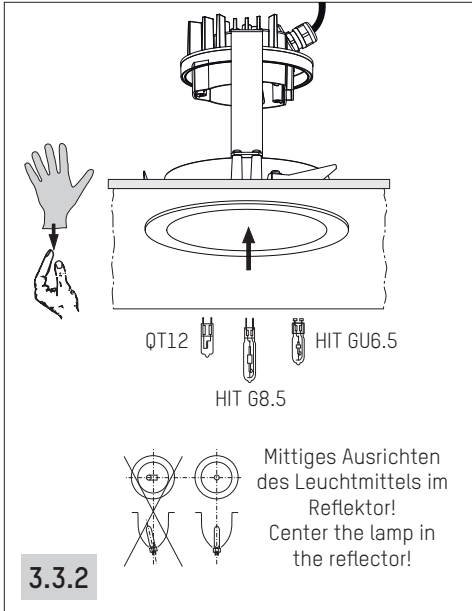

COMPLX.100

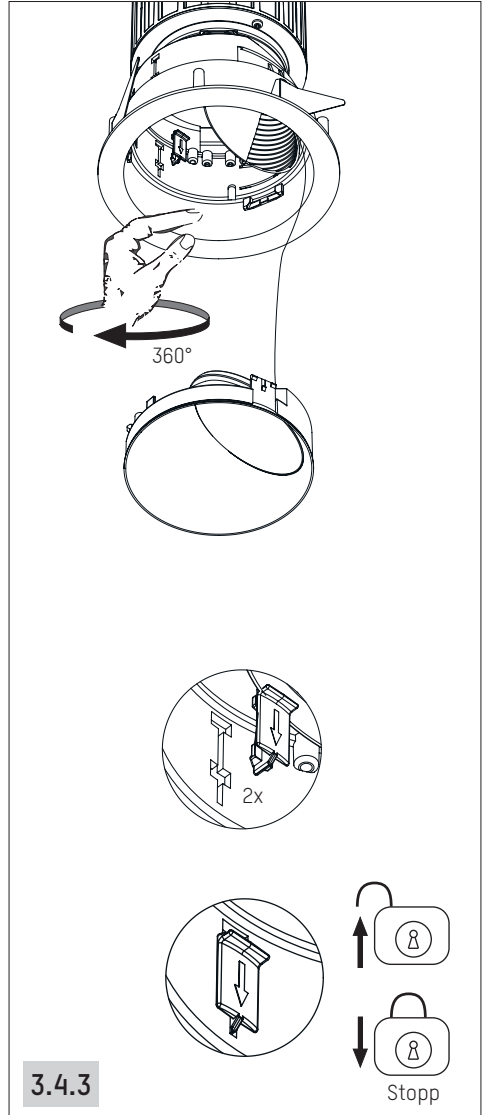
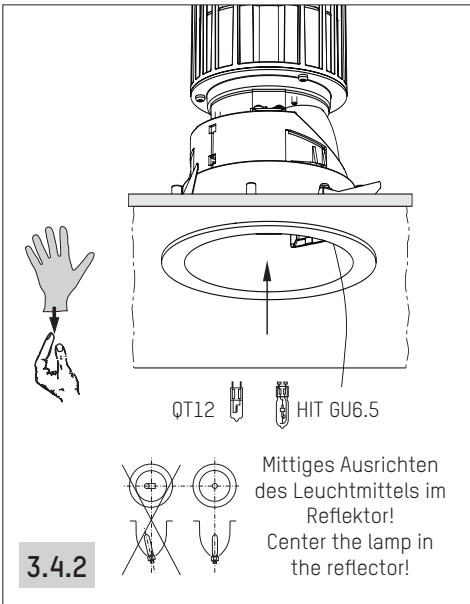
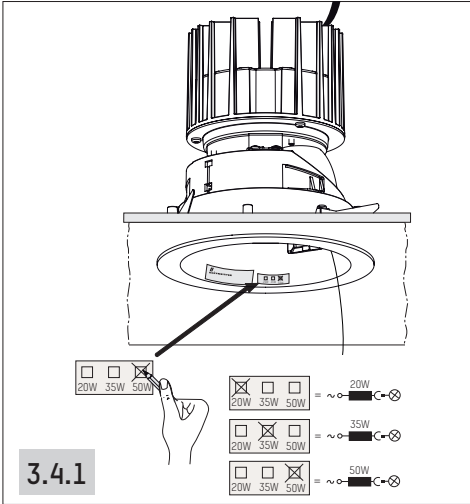

COMPLX.100

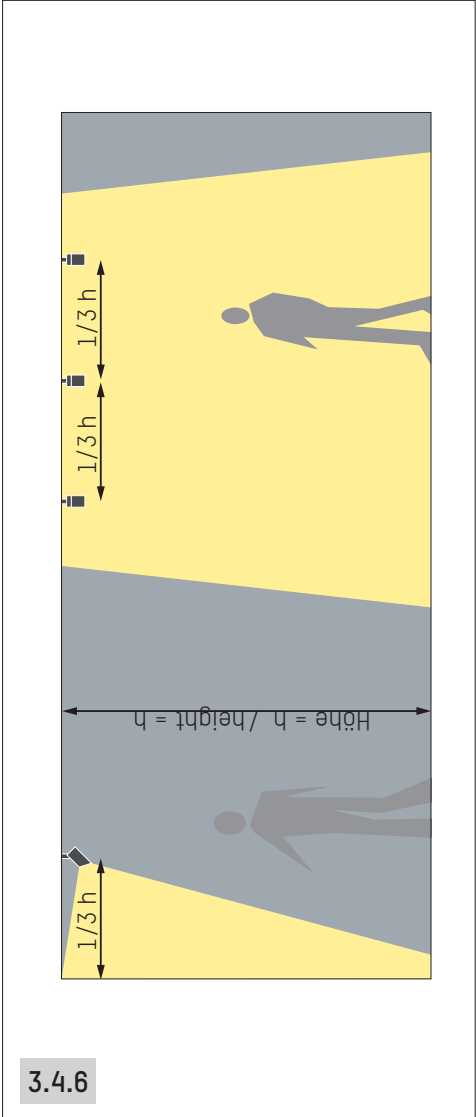
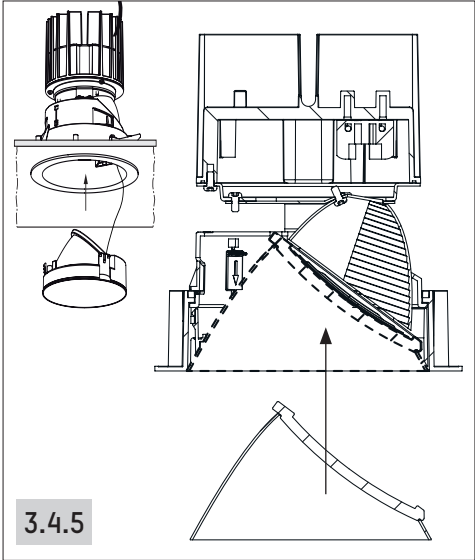

COMPLX.100



DIR/ directional luminaire

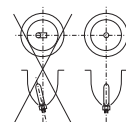
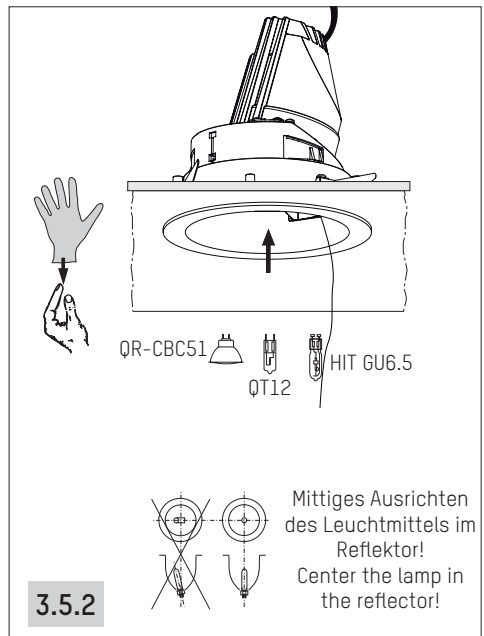
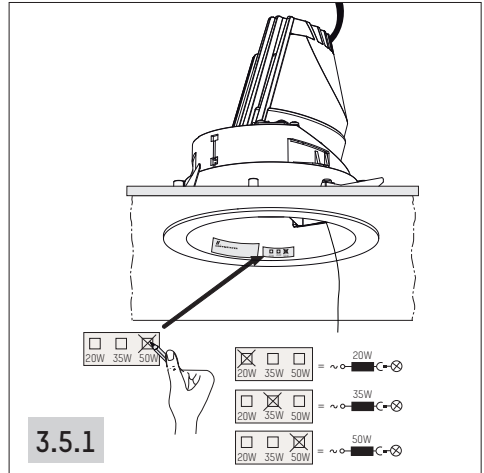
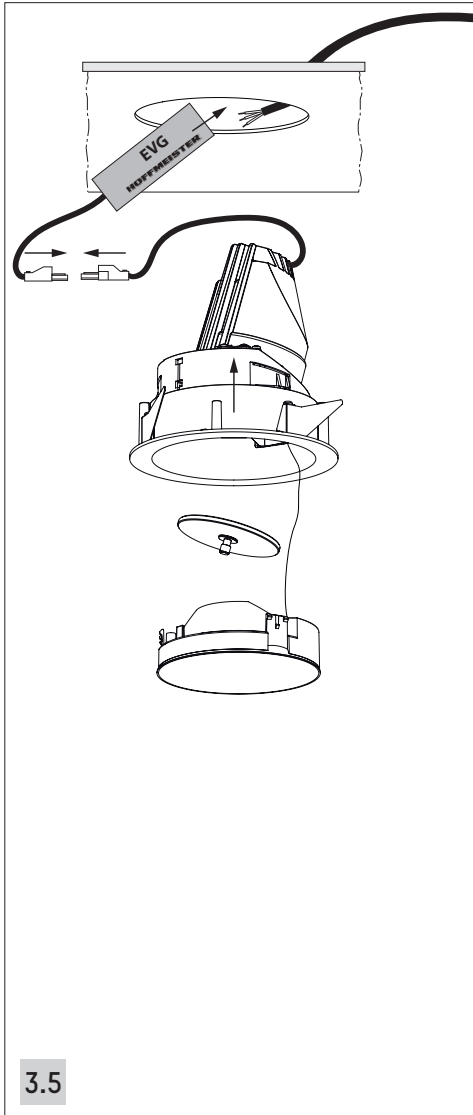

Mittiges Ausrichten
des Leuchtmittels im
Reflektor!
Center the lamp in
the reflector!

COMPLX.100

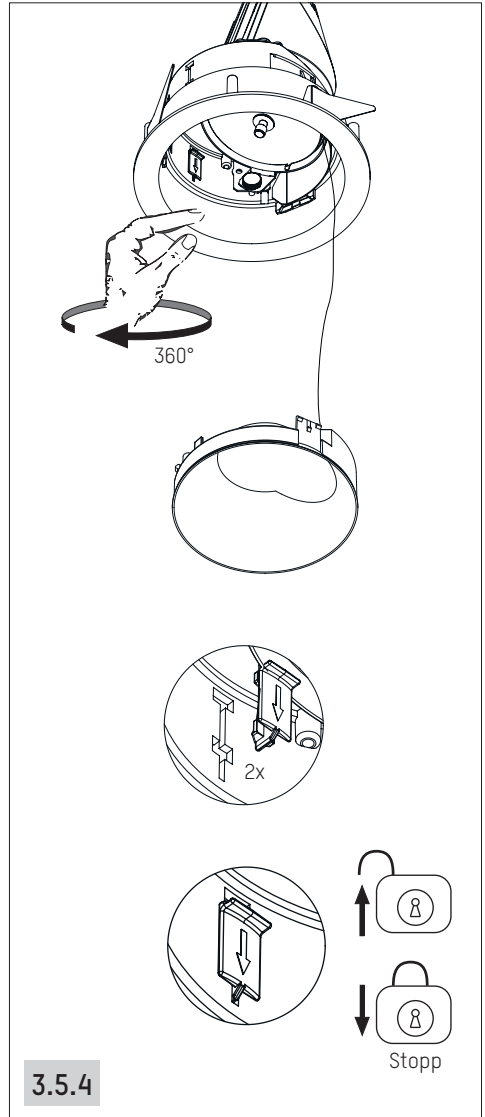
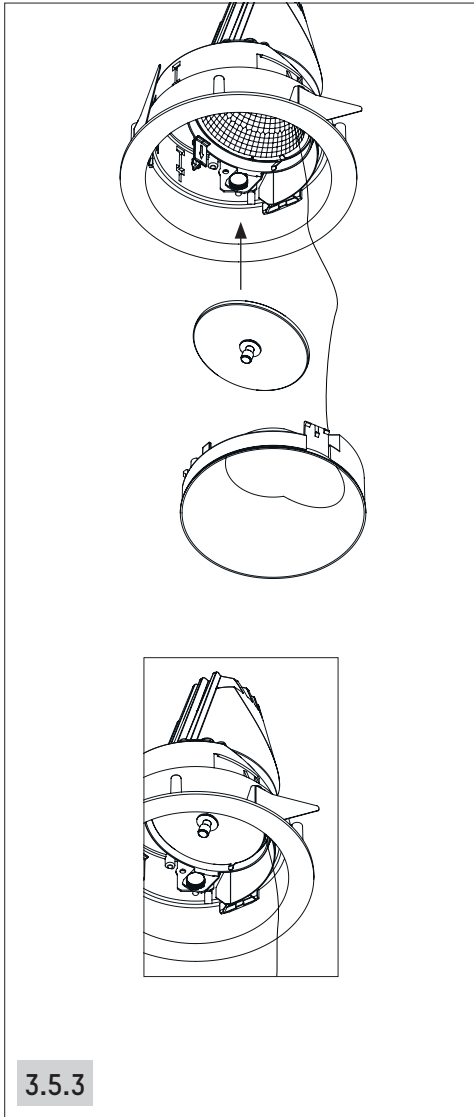

COMPLX.100

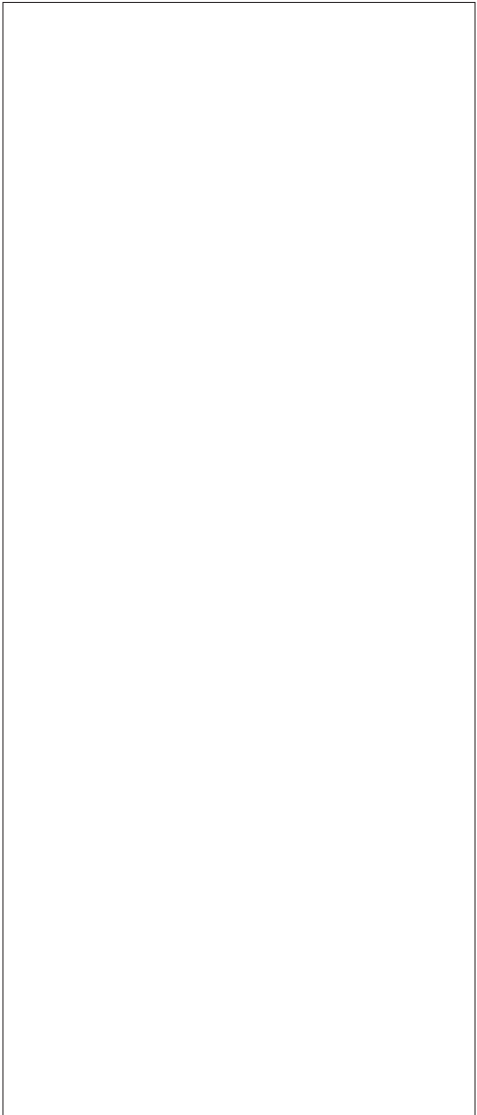
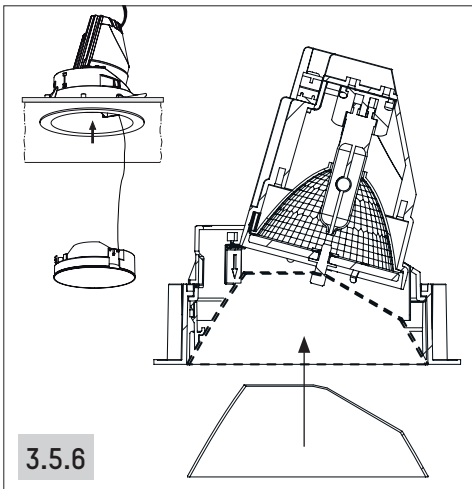
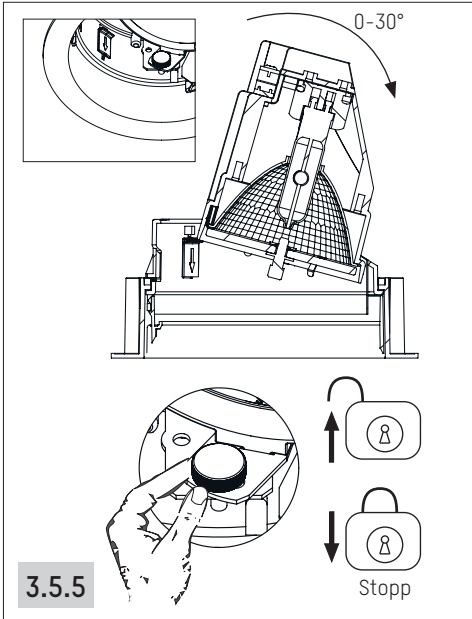

COMPLX.100**LED:**

Zur Vermeidung von Gefährdungen darf eine beschädigte äußere flexible Leitung dieser Leuchte ausschließlich vom Hersteller, seinem Servicevertreter oder einer vergleichbaren Fachkraft ausgetauscht werden.

To avoid hazards, a damaged flexible outer cable of this lamp may only be replaced by the manufacturer, its service representative or a comparable specialist.

Die Lichtquelle dieser Leuchte darf nur vom Hersteller oder einem vom ihm beauftragten Servicetechniker oder einer vergleichbaren qualifizierten Person ersetzt werden.

The light source of this lamp may only be replaced by the manufacturer or by a service technician appointed by the manufacturer or by a comparable qualified person.

COMPLX.100

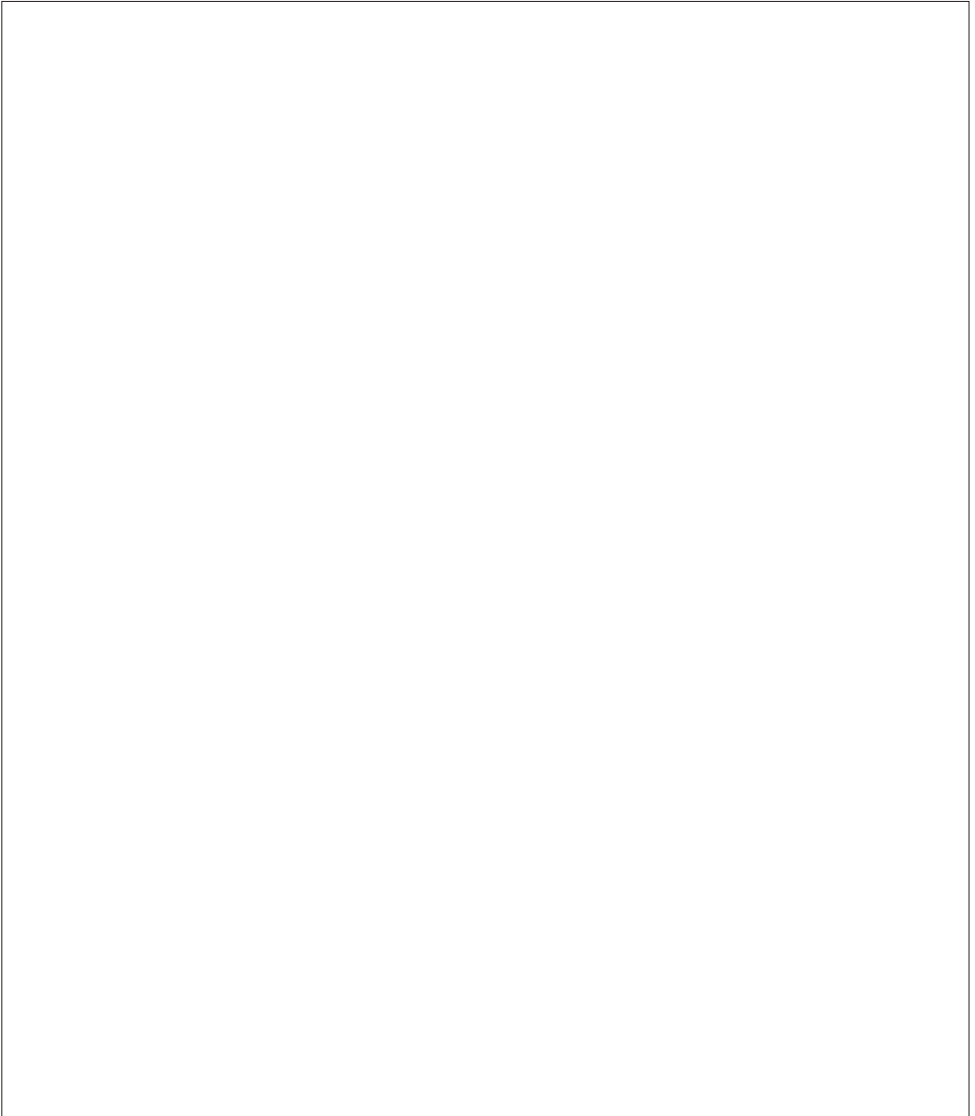

HOFFMEISTER

HOFFMEISTER LEUCHTEN GmbH
Gewerbering 28-32
58579 Schalksmühle
Germany
Phone: +49 (0) 2355-50 41-0
Fax: +49 (0) 2355-50 41-328
www.hoffmeister.de
mail@hoffmeister.de

Original **HOFFMEISTER**-Produkt - deshalb nur Original **HOFFMEISTER** - Teile verwenden.

This is an original **HOFFMEISTER** product - therefore use original **HOFFMEISTER** parts only.

Ceci est un produit d'origine **HOFFMEISTER** - pour cette raison, utilisier uniquement des pièces d'origine **HOFFMEISTER**.

Eso es un producto original **HOFFMEISTER** - por eso utilizar solamente piezas de recambio originales **HOFFMEISTER**.

Questo è un prodotto originale **HOFFMEISTER** - per questo impiegare esclusivamente ricambi originali **HOFFMEISTER**.

Unsere Gewährleistung gilt nur bei Beachtung dieser Produktinformation.

Sie erlischt insbesondere bei:

- Nichteinhaltung der Montagehinweise
- Veränderung der Leuchte
- Nichtbeachtung der Einbaumaße

Our guarantee is contingent upon the observance of this product information.

In particular it does not apply in cases of:

- noncompliance with mounting instructions
- modification of the luminaire
- nonrespect of recessing dimensions

Notre garantie dépend de l'observation de cette information sur le produit.

Elle s'éteint notamment dans les cas suivants:

- non-observation des instructions de montage
- modification du luminaire
- non-respect des dimensions d'encastrement

Nuestra garantía depende de la observación de esta información sobre el producto.

Prescribe particularmente en los casos siguientes:

- no observación de las instrucciones de montaje
- modificación de la luminaria
- inobservancia de las dimensiones de empotrado

Nostra garanzia è dipendente della osservanza di questa informazione di prodotto.

Perde la validità particolarmente nel caso di:

- inosservanza dei istruzioni di montaggio
- modificazione dell'apparecchio di illuminazione
- inosservanza dei dimensioni di incasso

Diesen Kontrollschein bei Reklamationen bitte mit zurückschicken.

In case of complaints please return this control label with the product.

En cas de réclamation veuillez retourner cette fiche de contrôle avec le produit.

En caso de reclamaciones, sirvase devol-vernors este talón de inspección junto con el producto.

Rispedire questa bolletta di controllo insieme con il prodotto in caso di reclamo.

Produktions-Serie
Production series
Série de production
Serie de producción
Serie di produzione