

**119 501...**  
**119 502...**  
**119 503...**

**119 504...**  
**119 505...**

HOFFMEISTER LEUCHTEN GmbH  
 Gewerbering 28-30  
 58579 Schalksmühle  
 Germany

Phone: +49 (0) 23 55 - 50 41-0  
 Fax: +49 (0) 23 55 - 50 41-328

www.hoffmeister.de  
 mail@hoffmeister.de

Original **HOFFMEISTER**-Produkt - deshalb nur Original **HOFFMEISTER**-Teile verwenden.  
 This is a genuine **HOFFMEISTER** product - therefore use genuine **HOFFMEISTER** parts only.  
 Ceci est un produit d'origine **HOFFMEISTER**. N'utiliser donc que des pièces d'origine **HOFFMEISTER**.  
 Este es un producto original **HOFFMEISTER** - por tal razón, utilizar únicamente piezas originales **HOFFMEISTER**.  
 Prodotto originale **HOFFMEISTER** - utilizzare pertanto esclusivamente ricambi originali **HOFFMEISTER**.

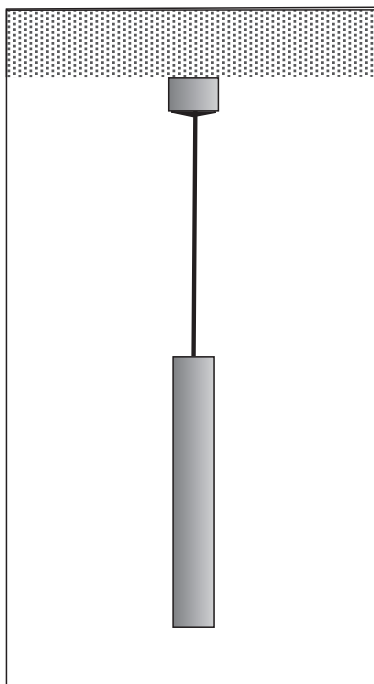

**Unsere** Gewährleistung gilt nur bei Beachtung dieser Produktinformation.

Sie erlischt insbesondere bei:

- Nichteinhaltung der Montagehinweise
- Veränderung der Leuchte
- Nichtbeachtung der Einbaumaße

**Our** warranty is contingent upon the observance of this product information.

In particular, it shall become null and void if

- the fitting instructions are not followed
- any modification is made to the luminaire
- the fitting dimensions are not observed

**Notre** garantie dépend de l'observation de cette information sur le produit.

Elle est exclue notamment dans les cas suivants:

- non-observation des instructions de montage
- modification du luminaire
- non-respect des dimensions d'encastrement

**Nuestra** garantía depende de la observancia de la información sobre el producto.

Se extinguirá particularmente en los siguientes casos:

- no observación de las instrucciones de montaje
- modificación de la lámpara
- inobservancia de las dimensiones de empotrado

**La nostra** garanzia è applicabile solo se vengono rispettate le indicazioni contenute nella presente informazione sul prodotto.

La garanzia decade in particolare in caso di:

- mancato rispetto delle istruzioni per il montaggio
- apporto di modifiche ovvero manomissioni all'apparecchio di illuminazione
- mancato rispetto delle dimensioni montaggio

119 441 02/2022

Diesen **Kontrollschein** bei Reklamationen bitte mit zurückschicken.

En cas de réclamation, prière de retourner ce **talon de contrôle** avec le produit.

En cas de réclamation veuillez retourner cette **fiche de contrôle** avec le produit.

En caso de reclamación, s'rvase devolvernos este **talón de control** junto con el producto.

In caso di reclami, inviare alla Casa il presente **tagliando di controllo** unitamente al prodotto

Produktions-Serie  
 Production serie  
 Série de production  
 Serie de producción  
 Serie di produzione

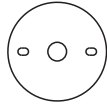

gehört nicht zum Lieferumfang  
not included / non compris  
non compreso / no incluido

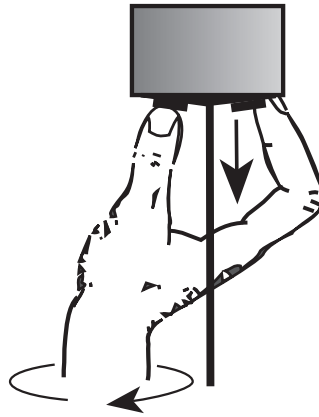
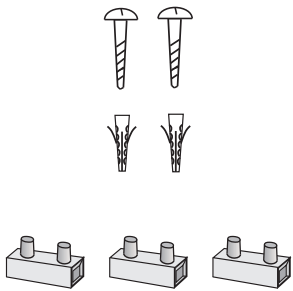

1

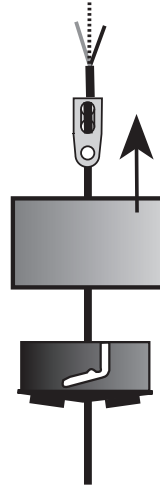

2

Nocken 2 x ausrasten  
unlatch pin 2 x  
came à déclipser 2x  
desencaja la leva 2 x  
aggancio a perno

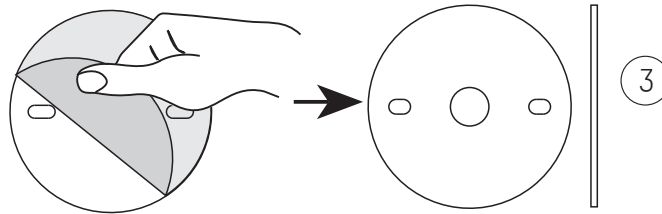
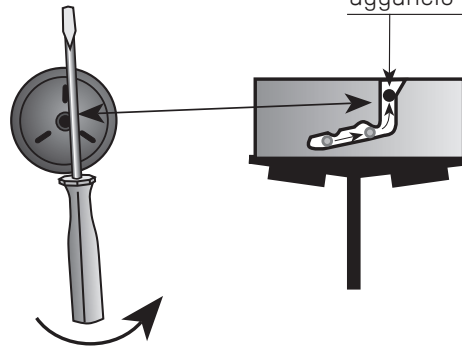

3

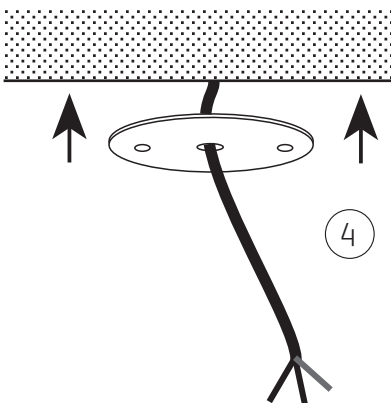

4

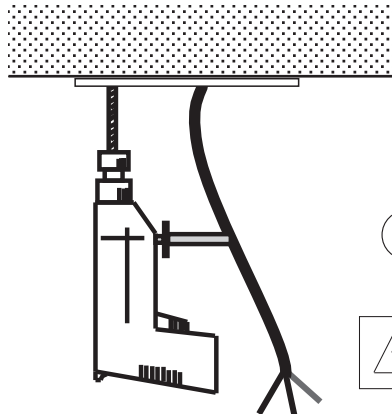

5

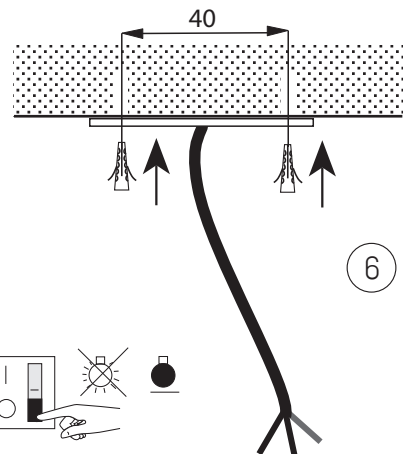

6

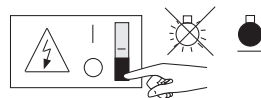

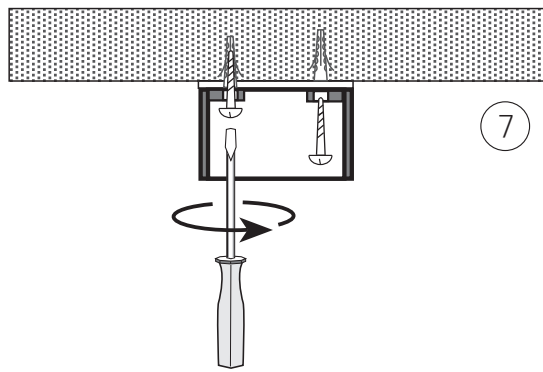

7

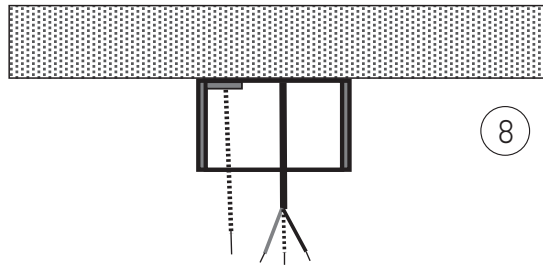

8

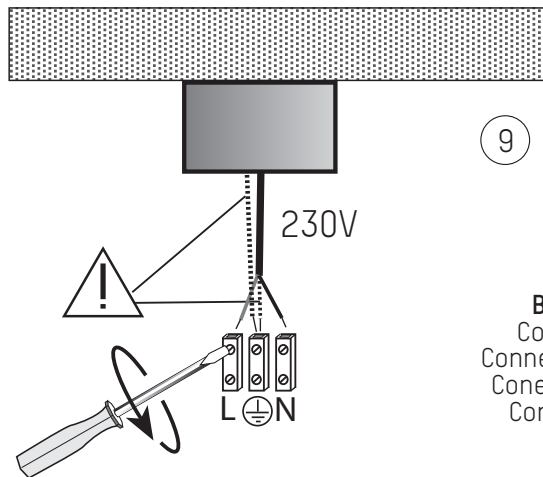

9

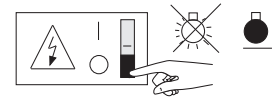

**Beide Erdleitungen anschließen.**  
 Connect both earthing conductors.  
 Connecter les deux conducteurs de terre.  
 Conectar los dos conductores de tierra.  
 Connettere i due fili di presa di terra.

**Mantelleitung auf gewünschte Länge kürzen, wieder durch Zugentlastung führen.**

Shorten the sheathed cable to required length, then re-insert in strain relief.  
 Raccourcir le câble à gaine à la longueur voulue, ensuite réinsérer dans le serre-câble.  
 Cortar el cable cubierto a la longitud deseada, pués reinsertar en la contratracción.  
 Accorciare il cavo alla lunghezza desiderata, poi ricollocare dentro di serracavo.

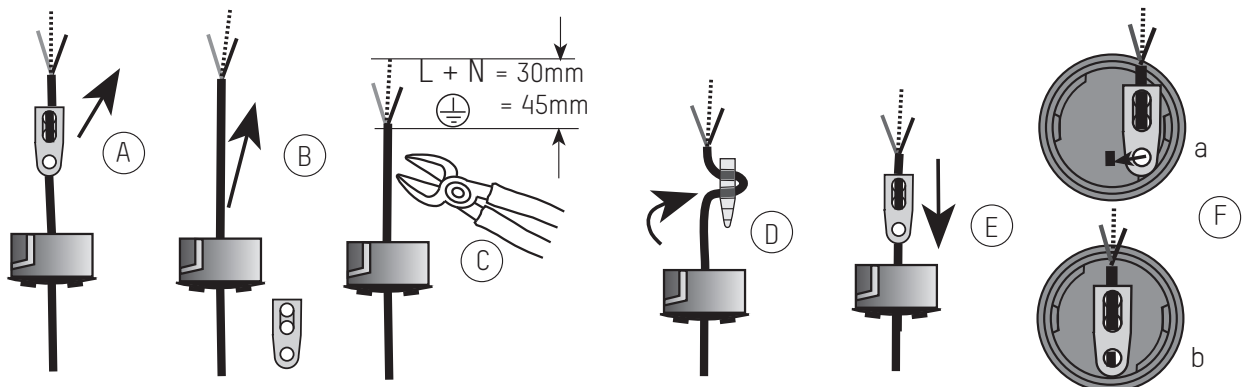

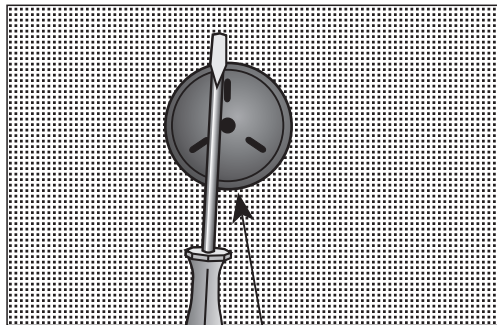
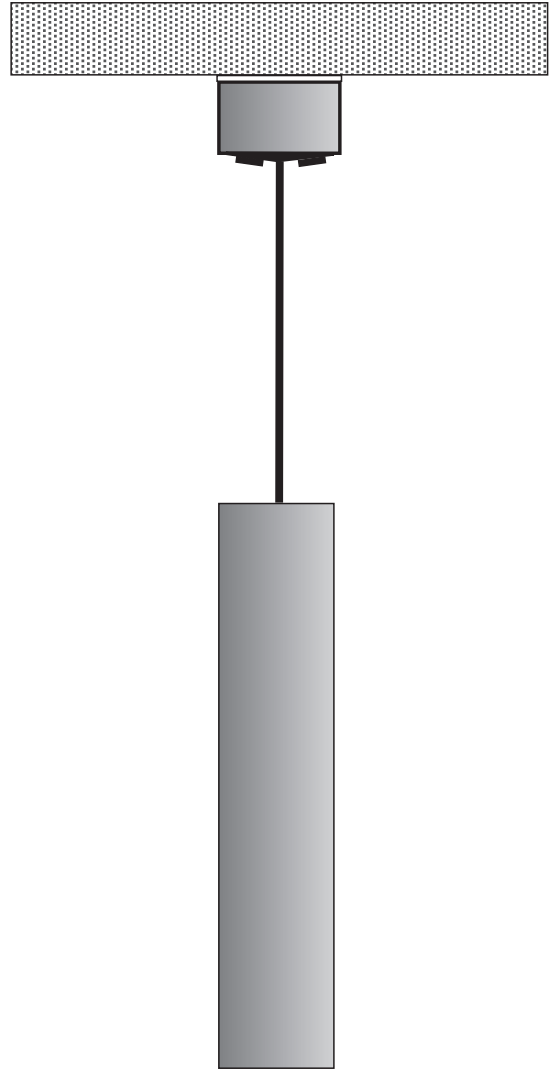
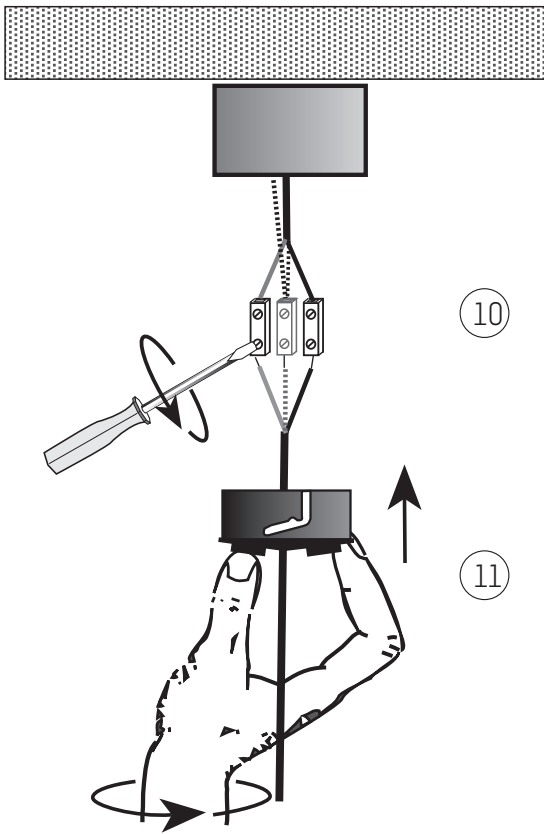

**Nocken 2 x einrasten**  
 latch pin 2x  
 came à enclencher 2x  
 encaja la leva 2 x  
 aggancio a perno

