

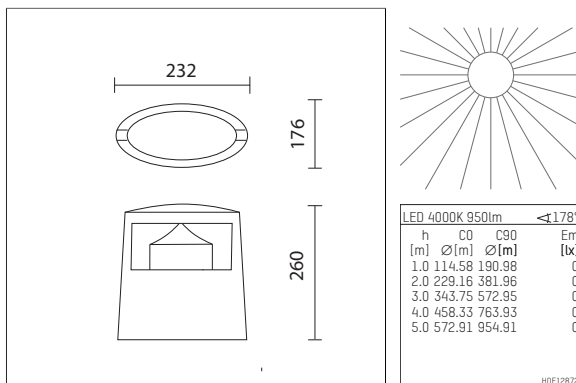

077 108 04 916 | silver

MP 260 | double sided
pathway luminaire
LED | 14 W 4000 K



- pathway luminaire MP 260 double sided
- for mounting on ground with sufficient load bearing capacity or with socket (sold separately)
- with LED 2000 lm
- colour temperature: 4000 K
- colour rendering index: CRI >90
- L85 / B10 (50.000h / ta 25°C)
- SDCM < 2
- net luminous flux: 950 lm
- total load: 14 W
- luminous efficacy: 67,9 lm/W
- asymmetrical light distribution
- double sided light output
- reflector of aluminium, silver anodised
- with built in LED power unit, electronic, 220-240 V, 50/60 Hz
- power supply: connecting terminal 3x2,5 mm²
- power connection with internal plug connection
- housing of cast aluminium
- safety glass, clear
- length: 232 mm, width: 176 mm, height: 260 mm
- weight: 4,4 kg
- protection rating: IP65
- protection class I
- 5 years Hoffmeister warranty
- Made in Germany
- maximum ambient temperature: 50 ° C
- certificates: manufactured according to DIN VDE 0711 / EN 60598, CE
- colour: silver
- 077 108 04 916

- Overview of accessories on the following page / s

077 108 04 916
accessory

Optional accessories

description accessory general	dimensions in mm	item number	pic.-No.
underground socket for pathway luminaires MP 260	LxWxH: 221 x 164 x 500	079 017 00 000	01

